

2.1 Identification data

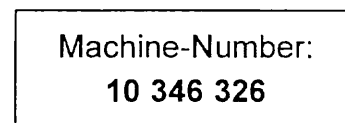

2.2 Machine type designation

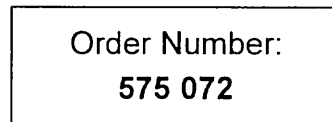
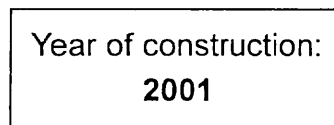
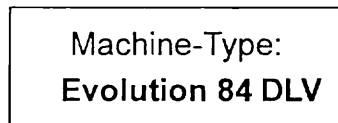
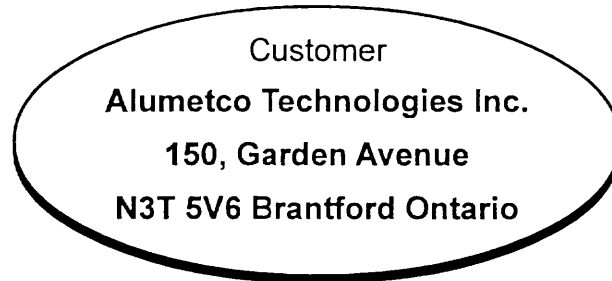
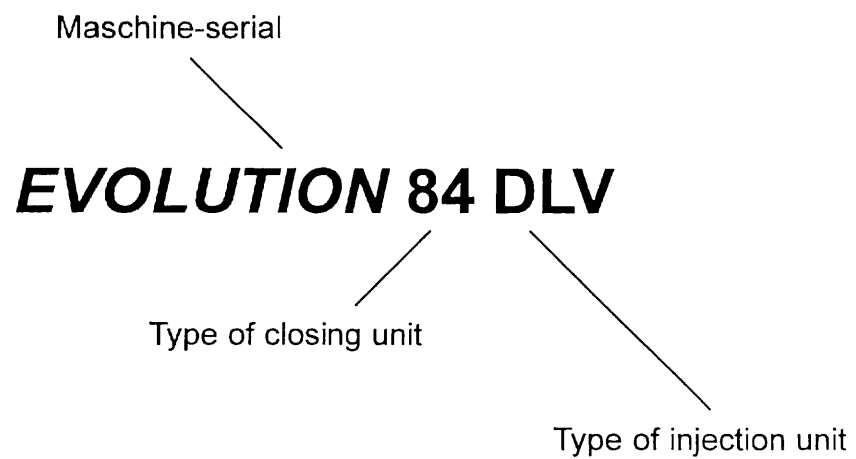

2.3 Directed use

Buhler horizontal die-casting machines are designed exclusively for the pressure die-casting of aluminium, magnesium, zinc and copper alloys. Any use beyond this scope is regarded as non-directed.

The manufacturer can **not** be made liable for any damages that are a result of non-directed use. The user is the sole bearer of the risk for such damage

The observance of the conditions for installation, start-up, operation and maintenance as instructed by the manufacturer are inherent with the directed use.

2.4 Ambience

In order to determine a suitable location for the DCM or DCI a number of important aspects will have to be taken into account.

See chapter „Preparing the site of installation“.

2.5 Electrical connections

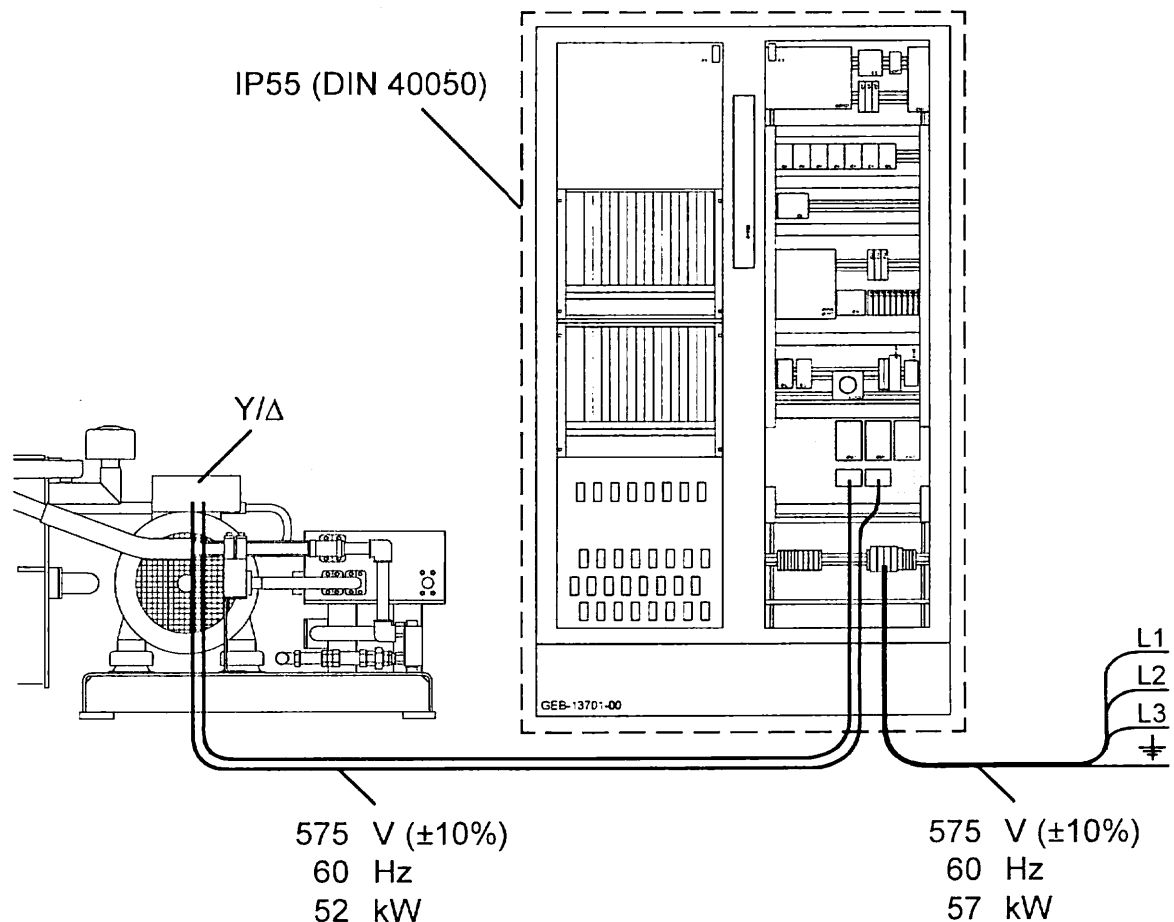

2.6 Dimension / Weight

Machine ready for production:..... 34'000 kg

Dimensions: see Encosures

Weight of the control cabinet:..... 275 kg

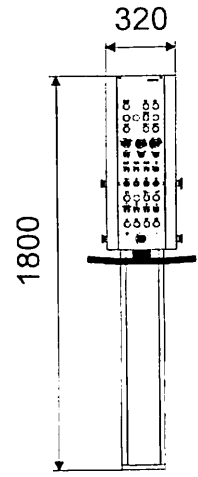
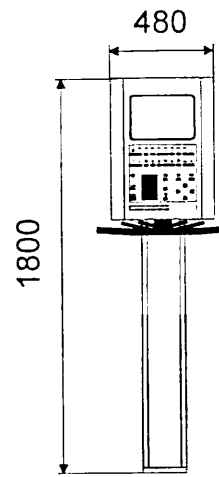
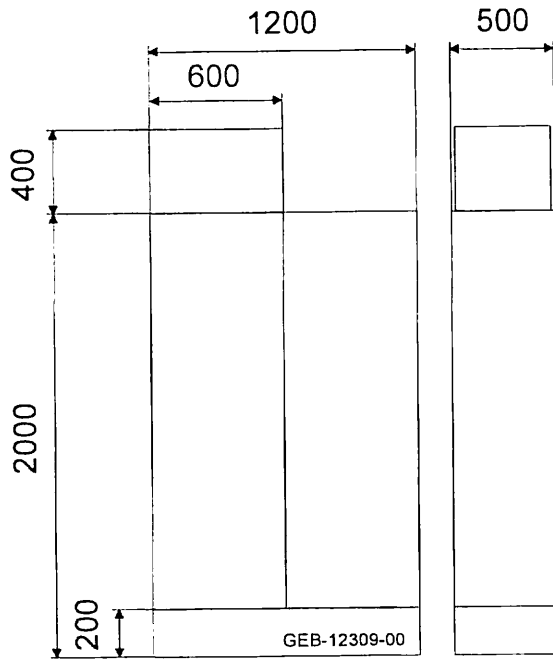

2.7 Driving unit / Hydraulics

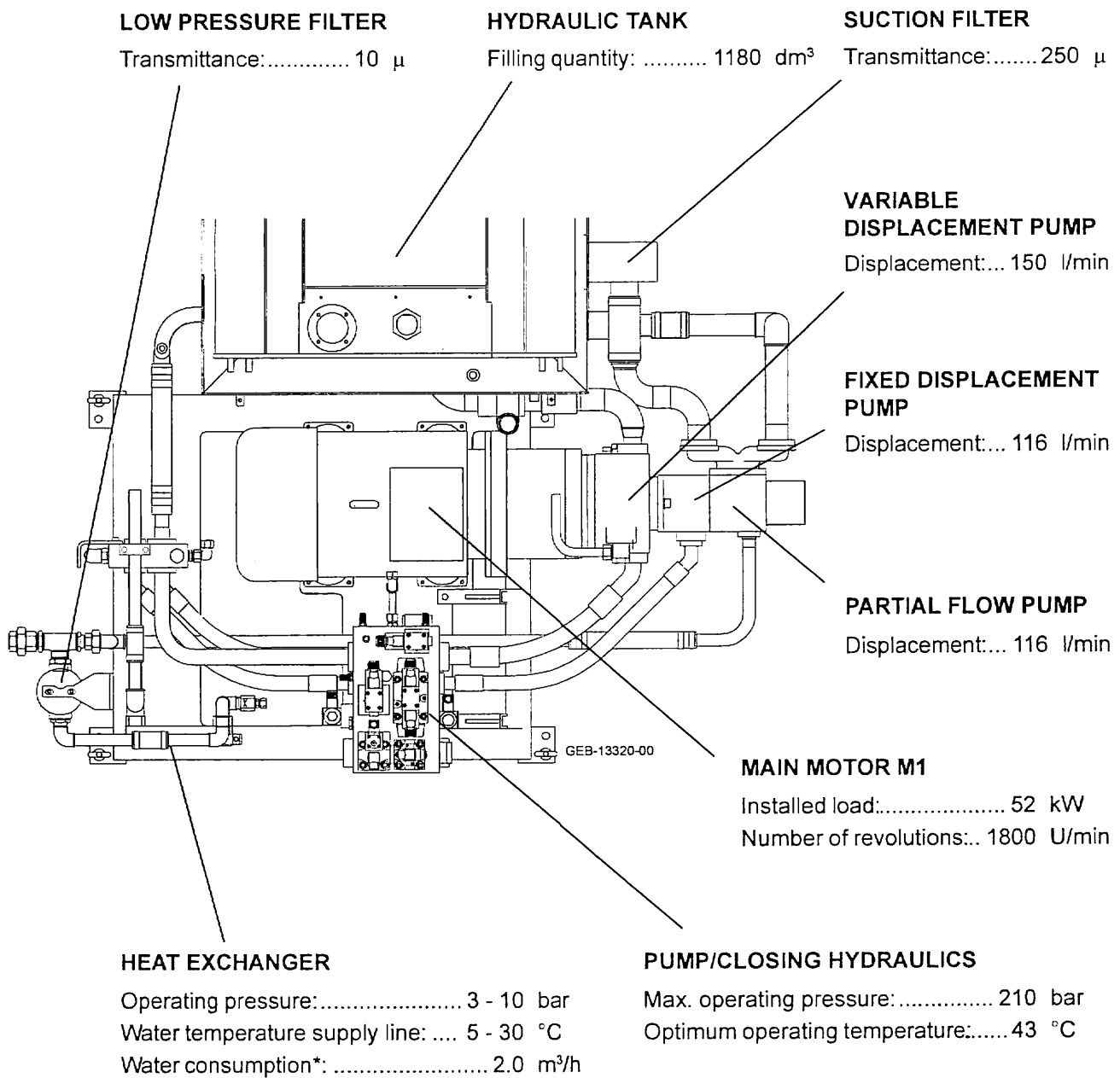

* Water consumption with a supply line temperature of 30°C

2.8 Closing unit

CENTRAL LUBRICATION

Filling quantity: 2.7 dm³

DIE

Die height: 400 - 1000 mm

Die opening stroke: 800 mm

Max. permissible surface pressure: 100 N/

Min. permissible die dimensions: .. 780 x 780 mm

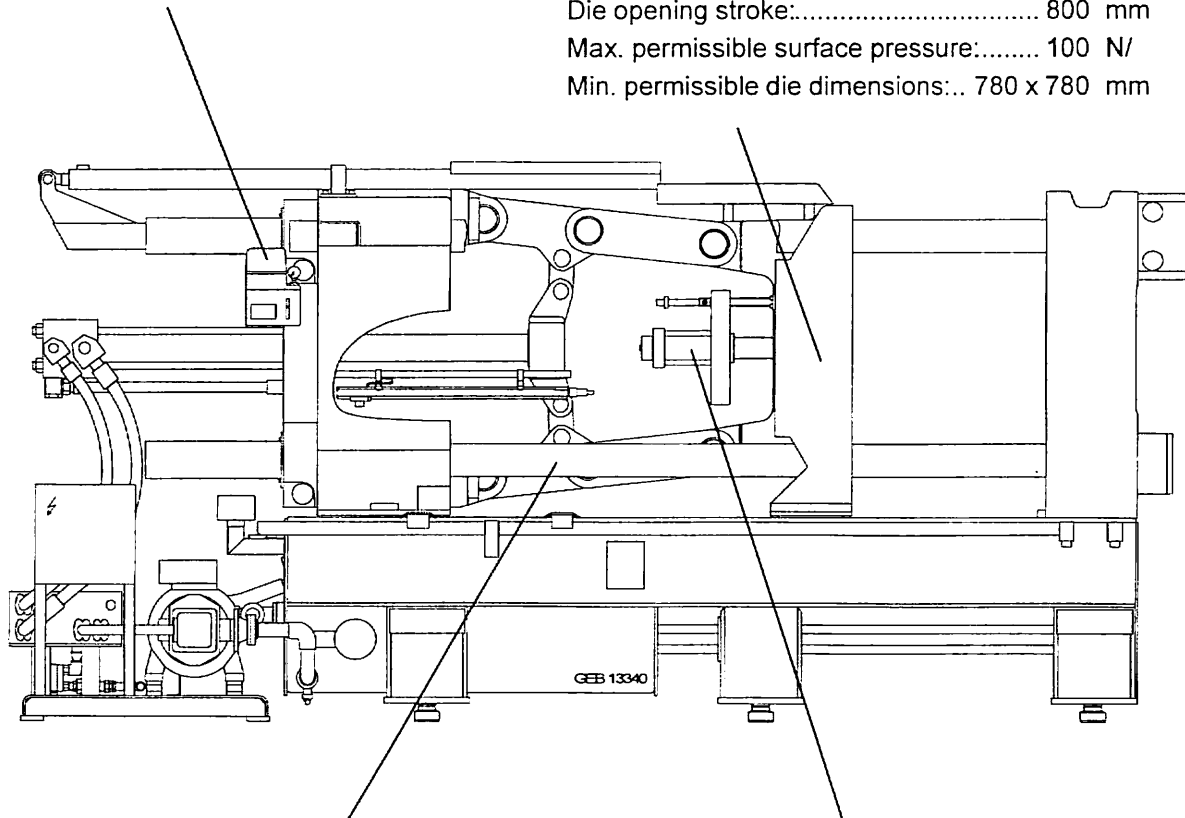

TIE BARS

Tie bar spacing: 1000 x 1000 mm

Tie bar diameter: 170 mm

Tie bar pulling from 0-Linie: 7200 mm

Tie bar removal from 0-Linie: 7200 mm

EJECTOR

Ejector stroke: 175 mm

Ejector force: 225 kN

LOCKING FORCE

Max. locking force with Lockmat: 9000 kN

Max. locking force without Lockmat: 9300 kN

0712 TECHNICAL DATA EVOLUTION OF DEJ

2.9 Shot unit

NITROGEN SYSTEM ACCUMULATOR

Filling quantity: 115 dm³
Max. idle pressure: 165 bar
Max. pressure accumulator charged: 210 bar

NITROGEN SYSTEM INTENSIFIER

Filling quantity: 38 dm³
Max. idle pressure: 185 bar
Area ratio: 1 : 2,25
Stroke: 115 mm

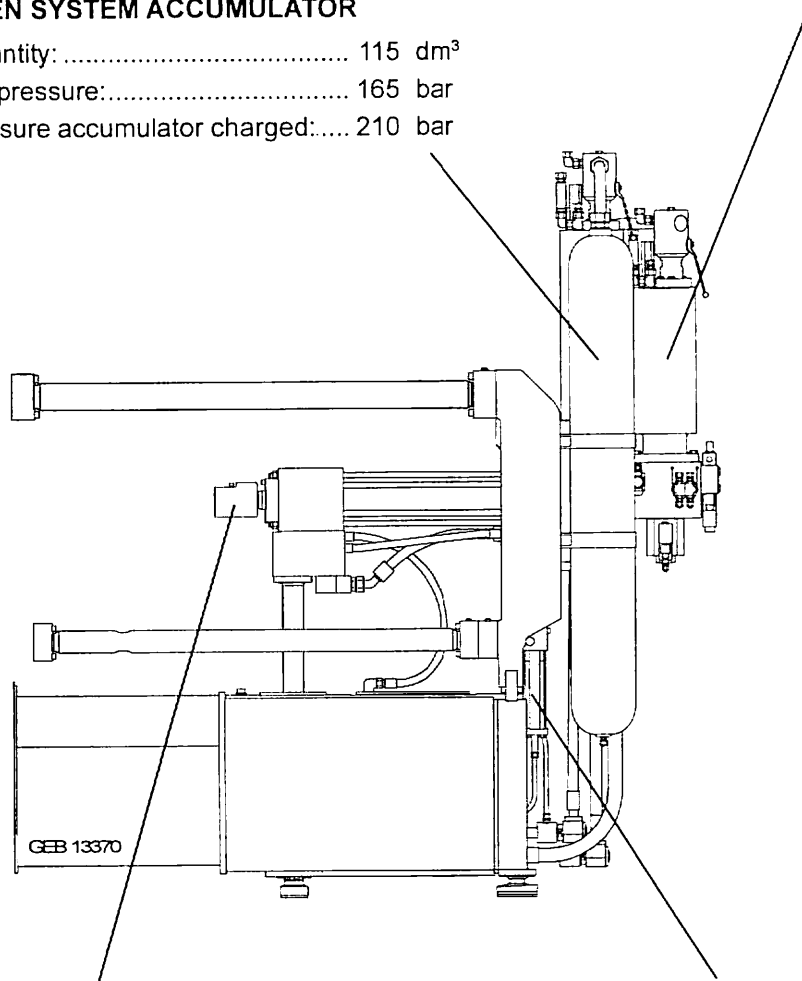

PLUNGER

Injection force dynamic: 290 kN
Injection force intensified: 700 kN
Plunger stroke: 600 mm
Plunger diameter: 70 - 110 mm

CASTING POSITION ADJUSTMENT

Casting positions: 0 / - 300 mm

PLUNGER LUBRICATION

Filling quantity: 10 dm³

2.10 Production data

Pluger Diameter	mm	70	80	90	100	110
Maximum Casting Volume	cm ³	1539	2011	2545	3142	3801
Maximum Casting Weight Al	kg	3.85	5.03	6.36	7.85	9.50
Maximum Metal Pressure	bar	1828	1399	1106	896	740
Maximum Projected Area	cm ²	509	665	841	1038	1257

SC D/84V

The maximum casting weight is calculated according to (DIN 22480):

$$\frac{2}{3} \times \text{Plunger Stroke} \times \text{Plunger Surface} \times \text{Density (Al 2,5 kg/dm}^3\text{)}$$

2.11 p/Q²-Diagram

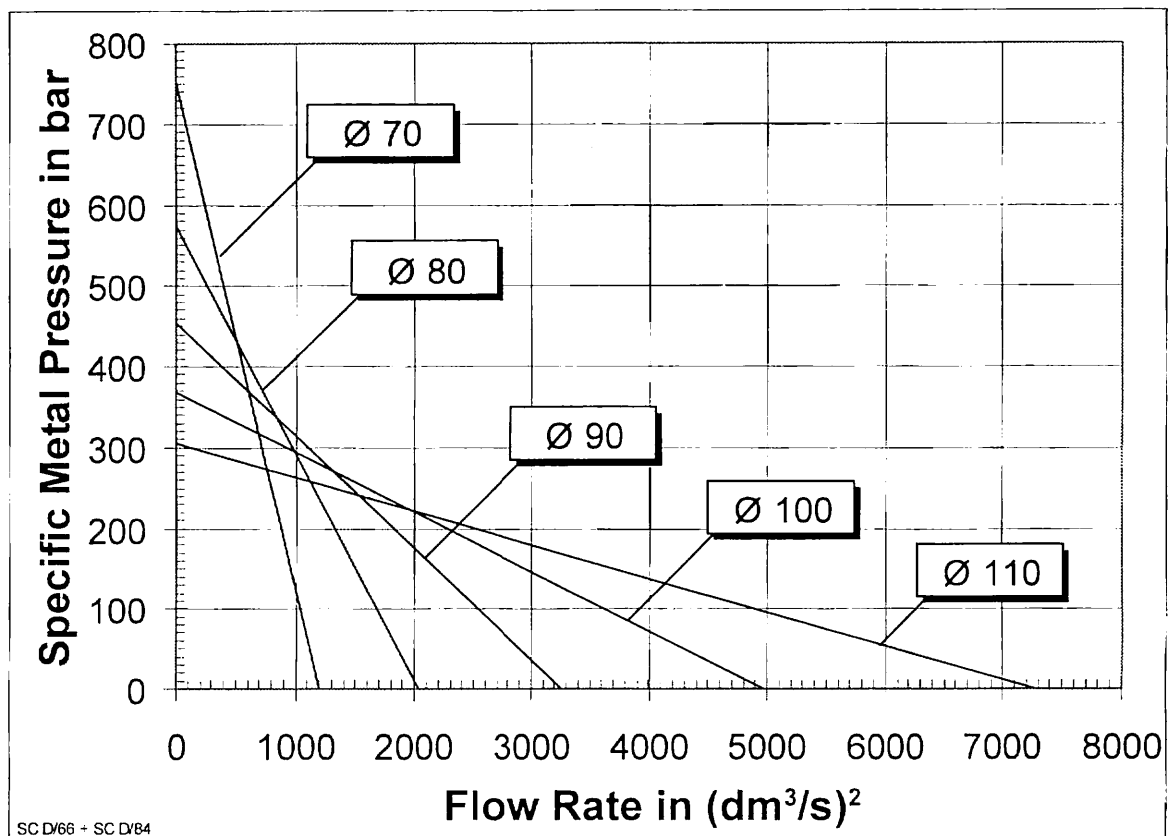

SC D/66 + SC D/84

2.12 Noise level of the DCM

Sound

Sources:

- the drive unit.
- during the casting process.

Depends on: machine load during operation.

Regulations: observe the local regulations.



WARNING!

If the noise emission is higher than the permissible values the personnel must wear appropriate ear protectors!

Measuring setup

- Casting process without metal (plastic plug). When casting with metal smaller pulse coefficients DLI eq (ca. 3dB) must be expected.
- Data are related exclusively to the DCM (without peripheral units).
- Measurements carried out according to DIN 45635 Section 1.
- Variations from the given values Leq and DLI eq are contingent to the operating conditions tCyc, vl and vl Br.

Results

Leq A-rating equivalent continuous sound level pressure at the working place including the pulse coefficient 79 dB(A)

DLI eq pulse coefficient 5 dB

Operating conditions

tCyc cycling time 30 s

vl plunger speed 5.0 m/s

vl Br braking velocity 1.0 m/s

2.13 Peripheral units

Please take the technical details of peripheral units from the relevant instruction manuals.

2.14 Enclosures

Checklist

Dimension sheets: Die-casting machine

Platens

Shot unit

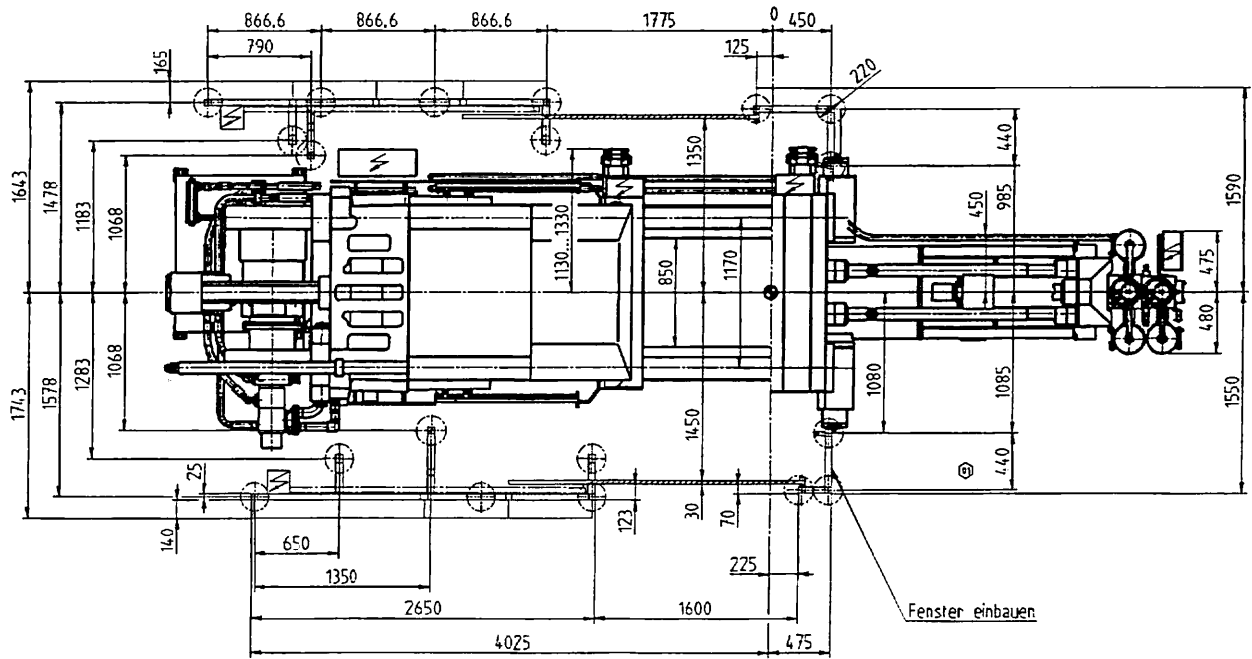
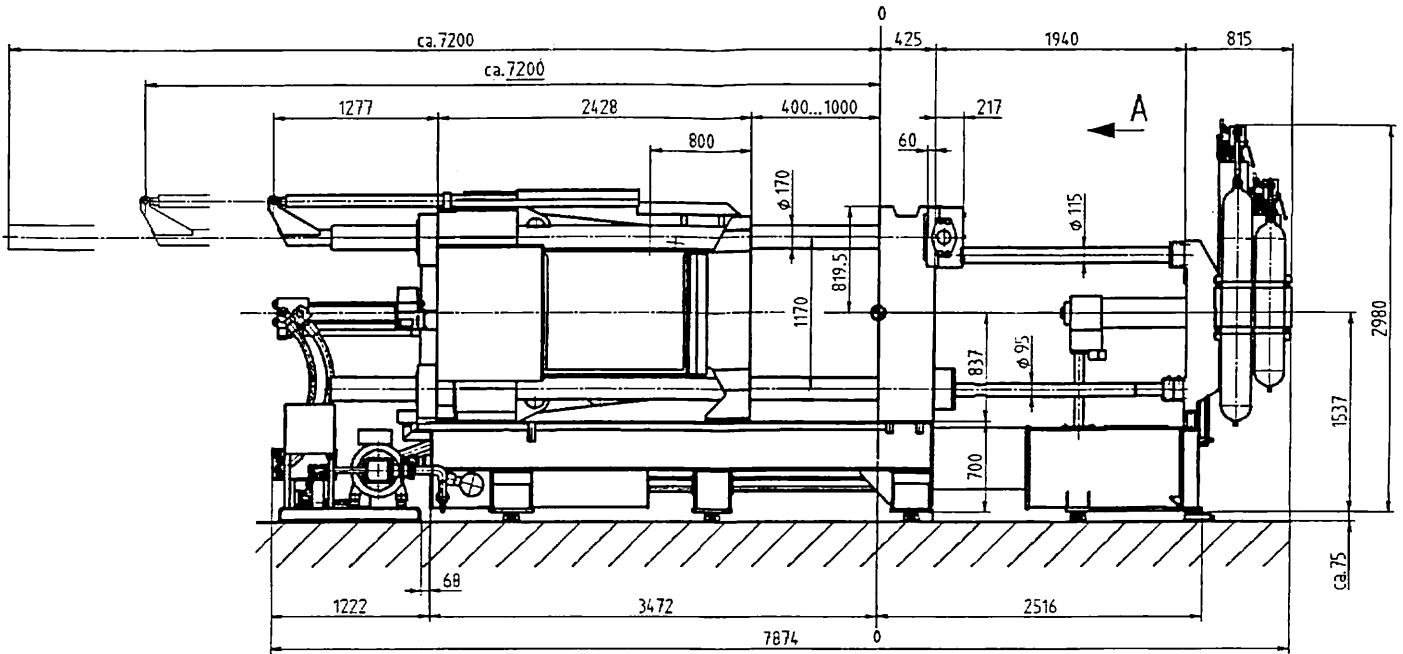

Bewegliche Aufspannplatte
 Plateau mobile
 Piastra mobile
 Moving die platen

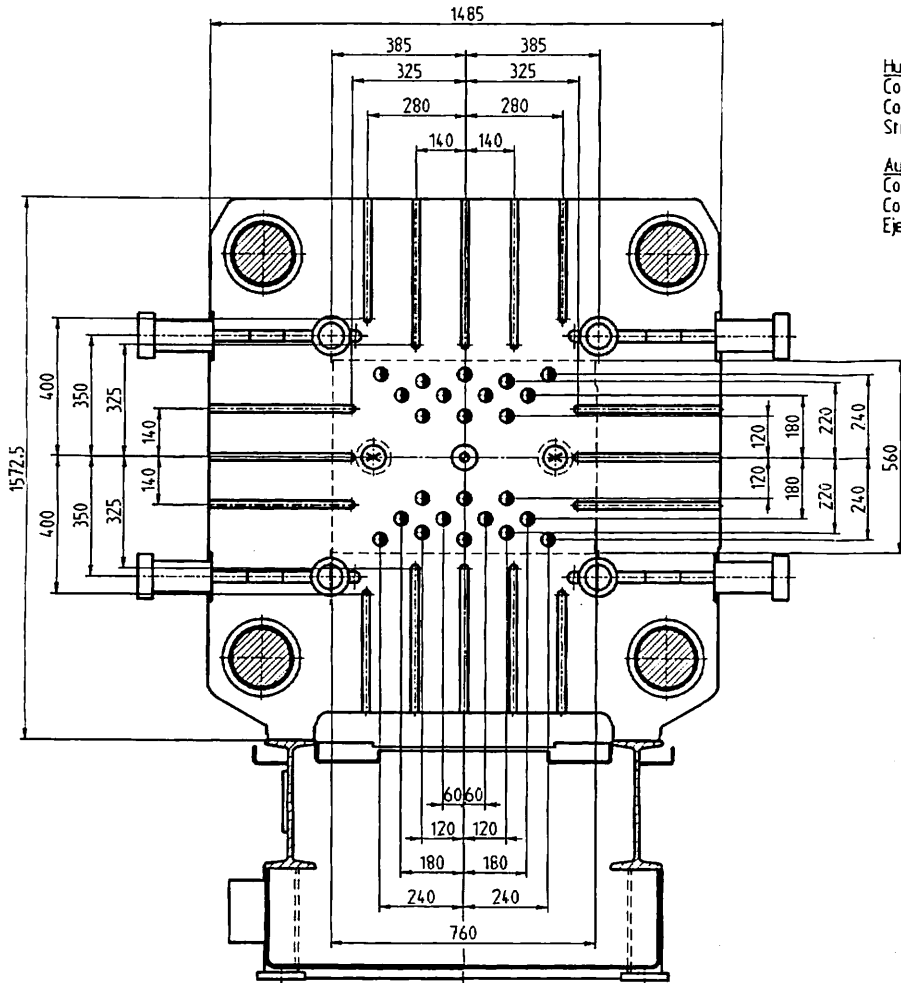

Hub der beweglichen Aufspannplatte max. 800
 Course du plateau mobile max.
 Corsa di piastra mobile max.
 Stroke moving die platen max.

Auswerfer regulierbar
 Course d'ejection réglable
 Corsa d'espulsione regolabile
 Ejector stroke adjustable

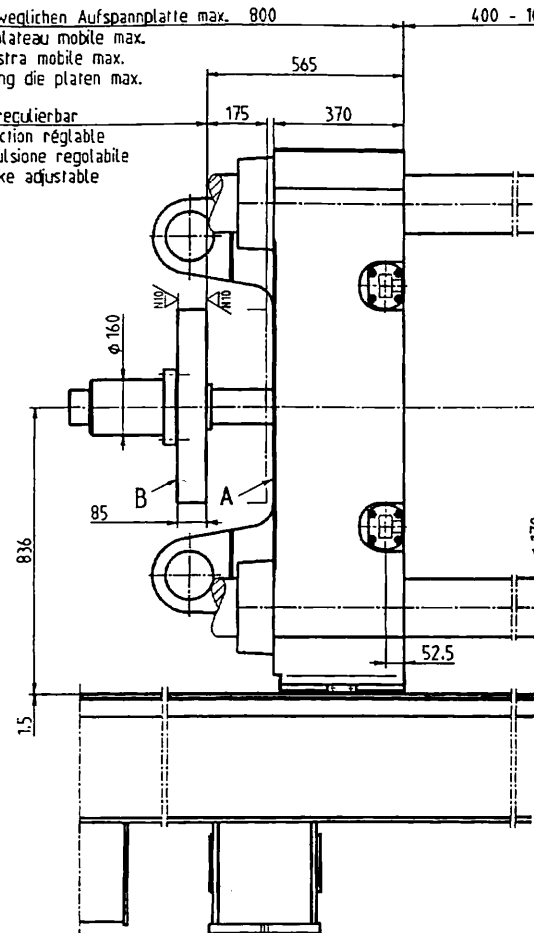

M 1:1

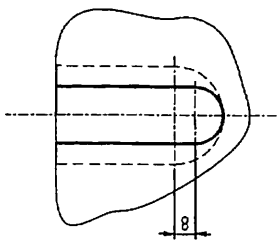

M 1:1

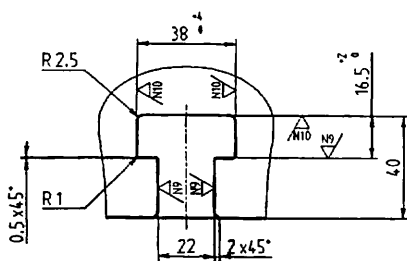

E - E M 1:5

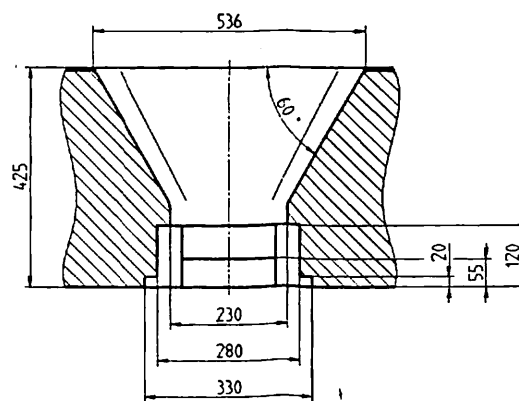

B M 1:2

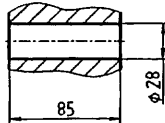

A M 1:2

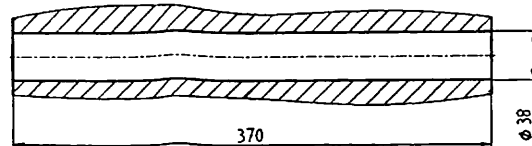

692

388

